

Bird's Eye Travel in North Carolina

Materials needed: road map of NC
calculator
ruler

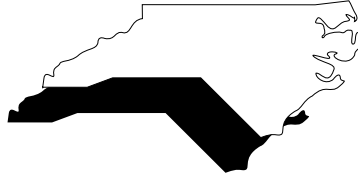

Answer the questions below “as-the-cardinal-flies,” that is, measure straight line distances between the points referred to and find distances based on the map scale. Good luck with your travels!

1. How far is it from the North Carolina capital of Raleigh to the town farthest away?
2. You are a great lover of the beaches and decide to make a trip from the port town of Wilmington to Cape Hatteras. How long is this trip?
3. If the mountains are more your taste, explore the high country. How far will you travel from Chimney Rock Park near Lake Lure to the highest peak east of the Mississippi, Mount Mitchell?
4. So you are a basketball fan? How far is it from the home of the Charlotte Bobcats to the UNC Tar Heels in Chapel Hill?
5. You are more into movies and TV? How far is it from Robbinsville, where *Nell* was filmed, to the town that inspired *The Andy Griffith Show*, Mt. Airy?
6. Travels are making you hungry. Where can you get some great food? Lexington is one of many towns famous for barbecue. From there try some seafood in the villages around Morehead City. How far would you have to travel between lunch in Lexington and dinner in Morehead City?
7. You are thirsty after dinner so you travel to the birthplace of Pepsi-Cola, New Bern, NC. While there you take in the grand old Tryon Palace in New Bern. Then you travel to another grand house, the Biltmore Estate in Asheville. How far is it between these two grand homes?
8. You are the scientific type, eh? How far is it to travel from Research Triangle Park to Kitty Hawk, where the Wright brothers flew the first airplane?
9. If it's ghosts and goblins that strike your fancy, try to get a peek at the Brown Mountain Lights near Morganton, (at the border of Burke and Caldwell counties on highway 181) and then visit the Haunted Red Man Inn in Old Salem. Old Salem is now part of Winston-Salem. For the next leg of your journey, find the Devil's Tramping Ground ten miles south of Siler City. Find the distance of each leg of this quest.
10. Now stretch all across North Carolina from Murphy to Manteo. What is this distance? If you were traveling on the road instead of flying on cardinal's back, about what proportion of your travel would be on interstate highway, and what percent would be on state roads? If you can travel 65 miles per hour on Interstate and about 50 miles per hour on state roads, how long would this cross-state trip take you?

Space Shuttle Landing Field

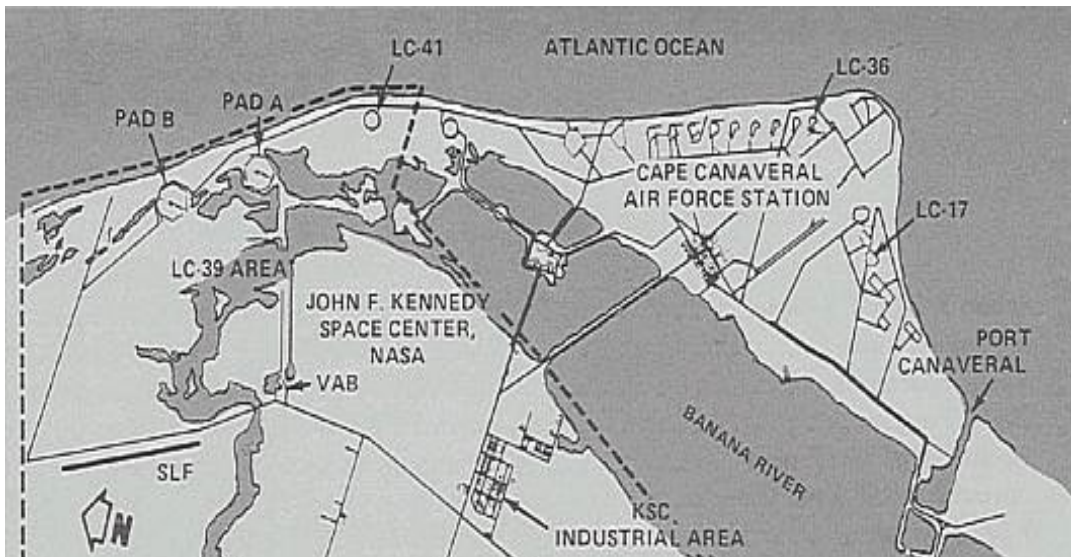

1. On this map of the Kennedy Space Center, VAB is the Vehicle Assembly Building and SLF is the Shuttle Landing Field. If the shuttle field is 4600 meters long and 91 meters wide, what is its area?
2. If a typical school bus is 12 meters long and 3 meters wide, how many could park on this landing field?
3. If the landing field is 4600 meters long, how far is it from the Vehicle Assembly Building to Pad B?
4. About how wide is the Banana River at the widest point shown on the map?
5. Estimate the area of the region outlined by dotted lines. Hint: Divide the region into approximate geometric shapes such as rectangles, triangles, trapezoids.

Building Blocks

Construct all the different blocks on the two sheets given to you. Find the surface area and volume of each one. **Construction Tips:** *Cut out the shapes and then score over the fold lines lightly with scissors. This will make the cardstock fold easier. Fold the shapes so that the grid is on the outside of the shape.*

<u>I. Shape</u>	<u>Surface Area</u>	<u>Volume</u>
-----------------	---------------------	---------------

Big prism		
-----------	--	--

Flat prism		
------------	--	--

Cube		
------	--	--

Triangular prism		
------------------	--	--

Now make new shapes by putting two blocks together at a congruent face. The two blocks must share an entire face.

Example

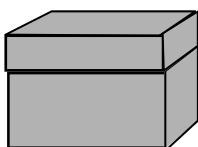

Incorrect example

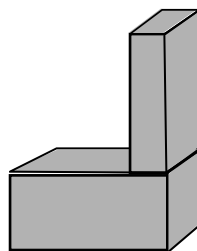

These two do not share an entire face.

II. Find 2-block shapes with the given volumes and surface areas.

	Volume (units ³)	Surface Area (units ²)
1.	864	648
2.	864	576
3.	648	458
4.	648	504
5.	648	476.4
6.	648	548.4
7.	432	404.4
8.	432	368.4

Record the shapes you find on isometric dot paper.

9. Which of the two block shapes has the smallest ratio of surface area to volume? Explain.

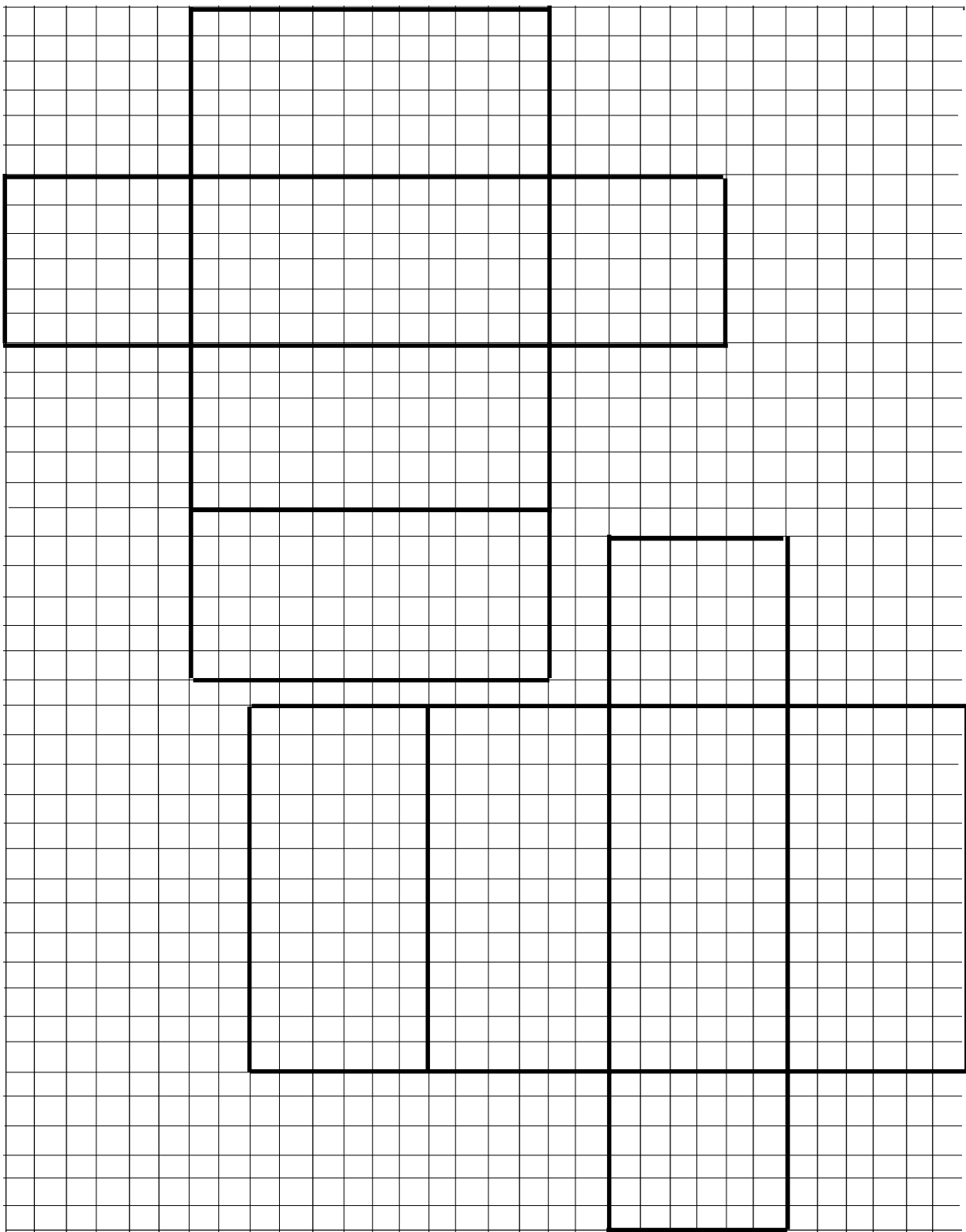

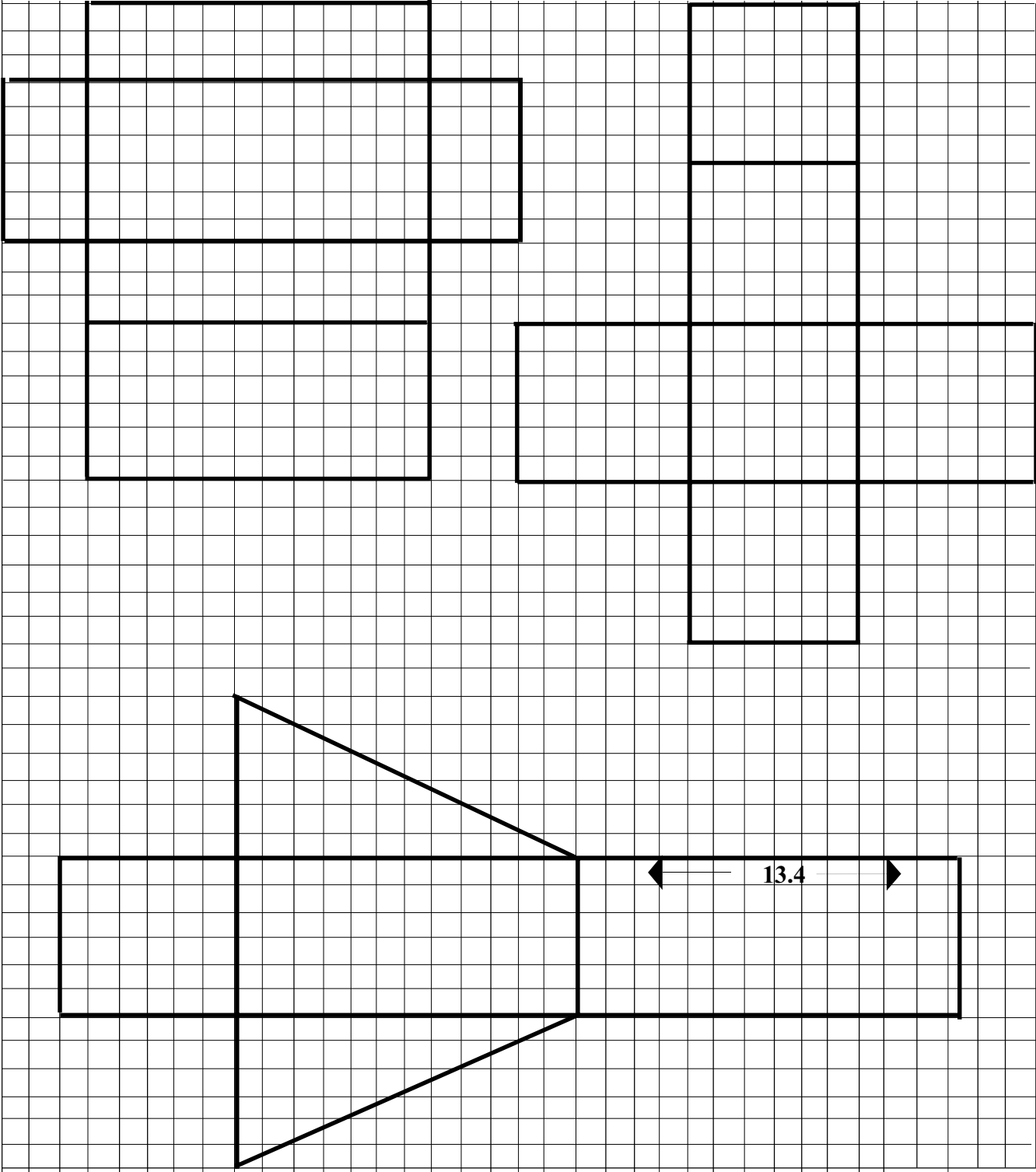

Name _____ Date _____

ISOMETRIC DOT PAPER

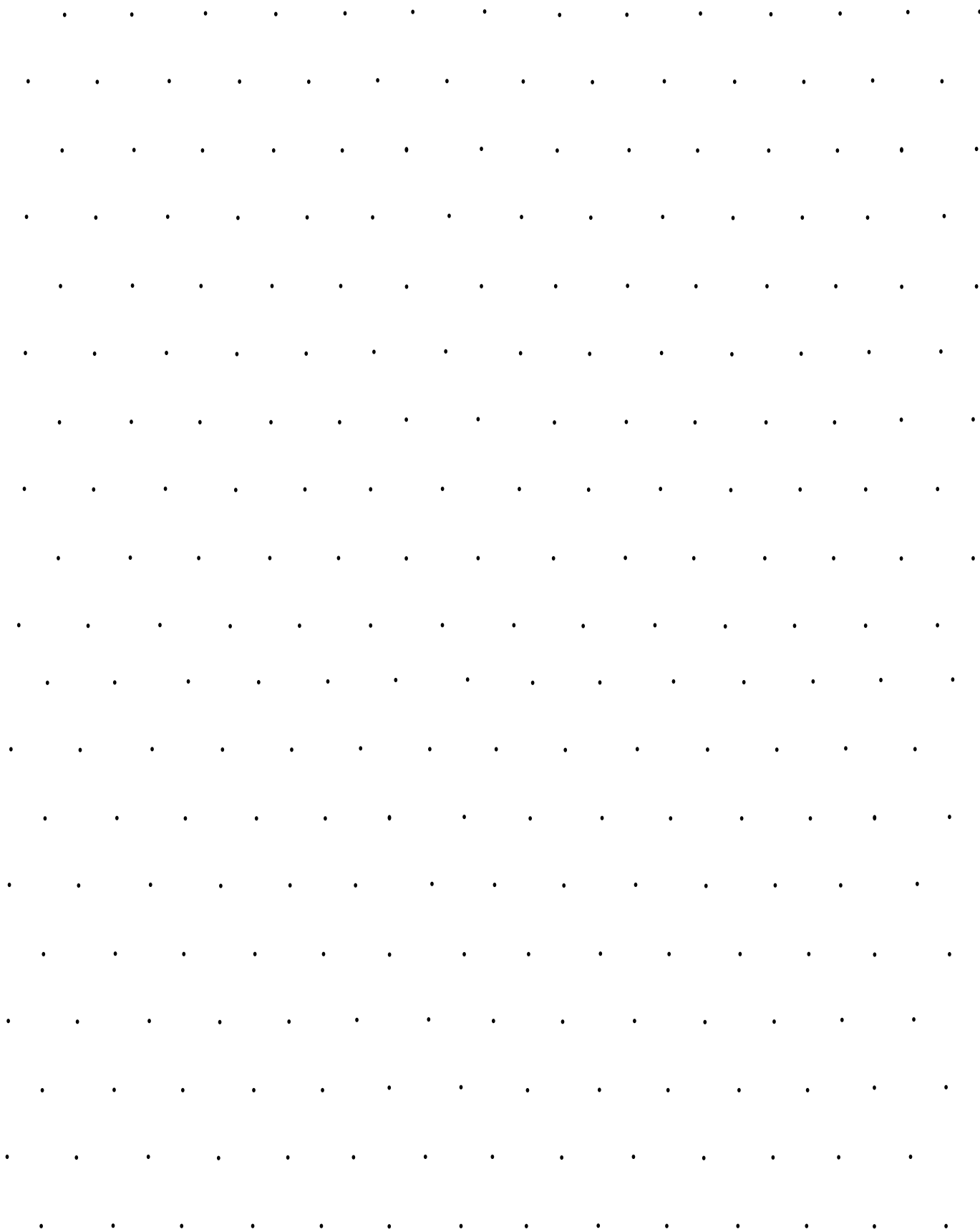

Models for Volume of a Prism

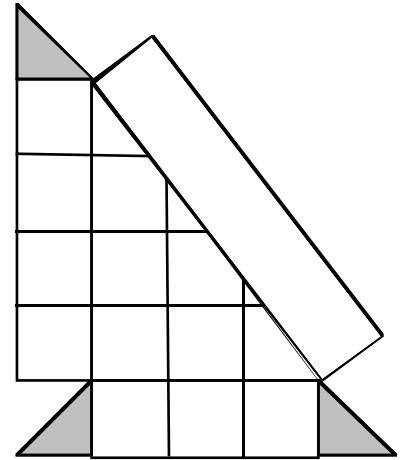
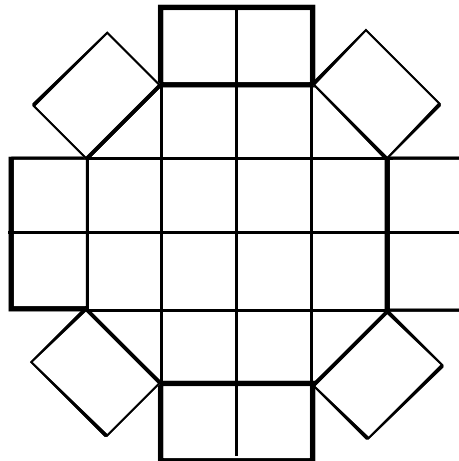
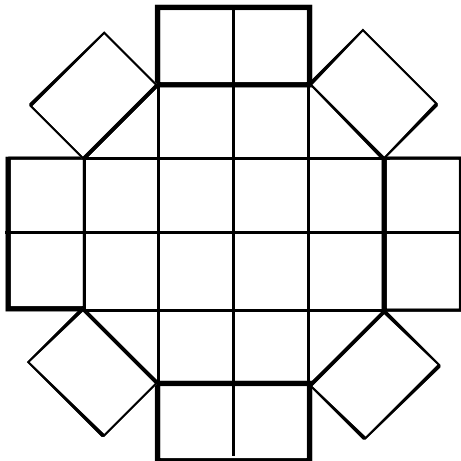
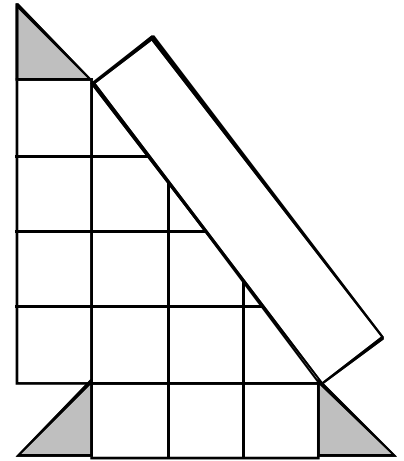
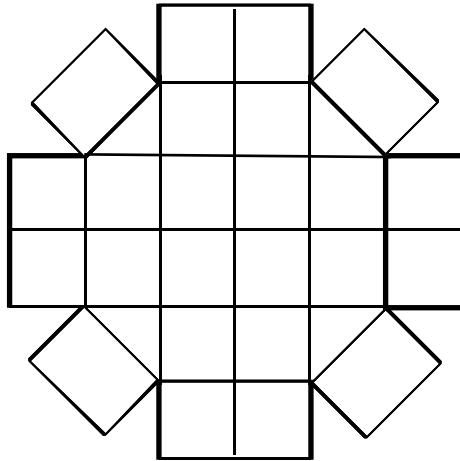
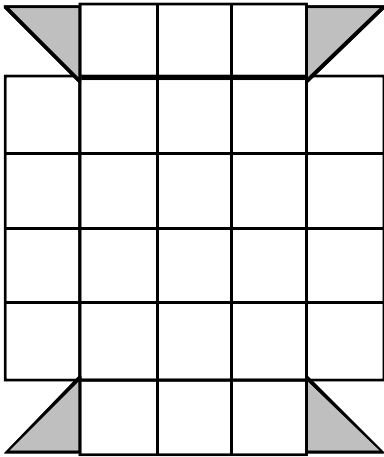
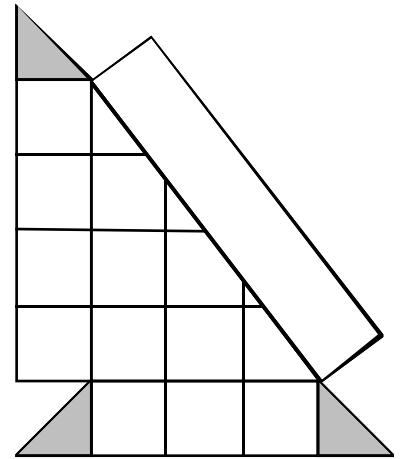
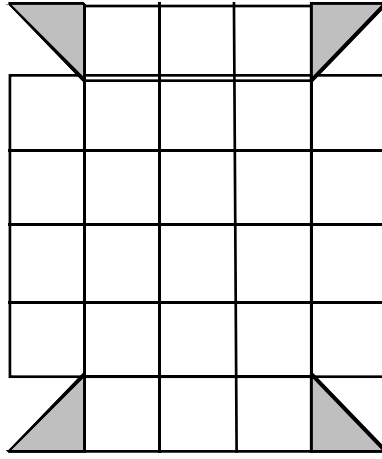
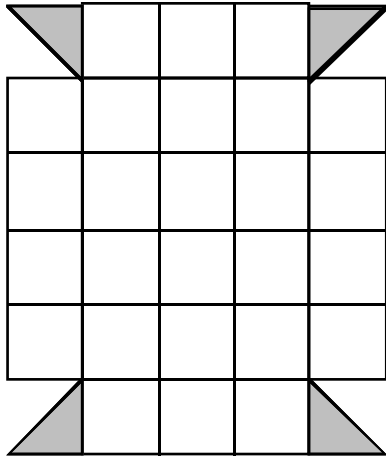

Harold's Can Design

1. Calculate the volume of the can. (Round to the nearest whole number.)

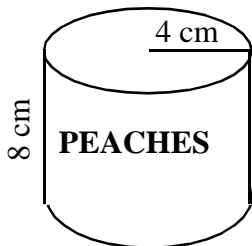

2. Harold wants to design a can to hold 500 ml.
- Explain why the volume of the can, V , is given by $V = \pi r^2 h$
 - Explain why the surface area of the can, S , is given by $S = 2\pi r^2 + 2\pi r h$
 - Harold decides to use a height of 10 cm.
 - Determine the radius. (Do not round yet.)
 - Determine the surface area of the can. (Round to the nearest whole number.)
 - Harold wants to find a design for the 500 ml can that will minimize the cost of the can (by minimizing the surface area). Complete the chart below. (Round the surface area to the nearest tenth.)

h(cm)	r(cm)	S(cm ²)
12.5		
10.0		
7.5		
5.0		
2.5		

- e. After analyzing the chart in 2d, explain which design Harold will use.

Gift Box Dilemma

Sam just purchased a candle to give to his mom as a birthday gift. Unfortunately, he has no box to put it in. Sam knows that he can make a box using tape and cardboard.

If he cuts the cardboard as shown below, he can fold and tape to make this box.

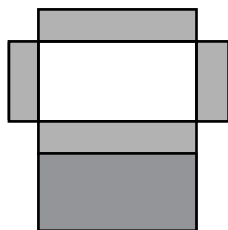

Sam's candle is 5 inches tall and has a radius of 1.5 inches. Draw a plan for his box below.

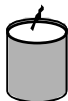

What are the dimensions of the box he should build? What is the surface area for this box?

Sam wants to purchase some special velvet coated cardboard to use for the box. The cardboard is sold at a craft store for 5 cents per square inch. What is the minimum Sam will have to pay for the cardboard?

If he finds a candle twice as tall, how will the surface area of the candle change? How will the surface area of the box change?

If he finds a candle with twice the radius, how will the surface area of the box change from the original? How will the surface area of the candle change from the original?

Sam decides to give his mom a set of four matching candles. He can pack them in either of the ways shown below. Calculate the surface area of boxes made to fit each case.

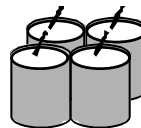
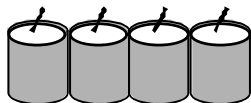

Name _____ Date _____

CONE

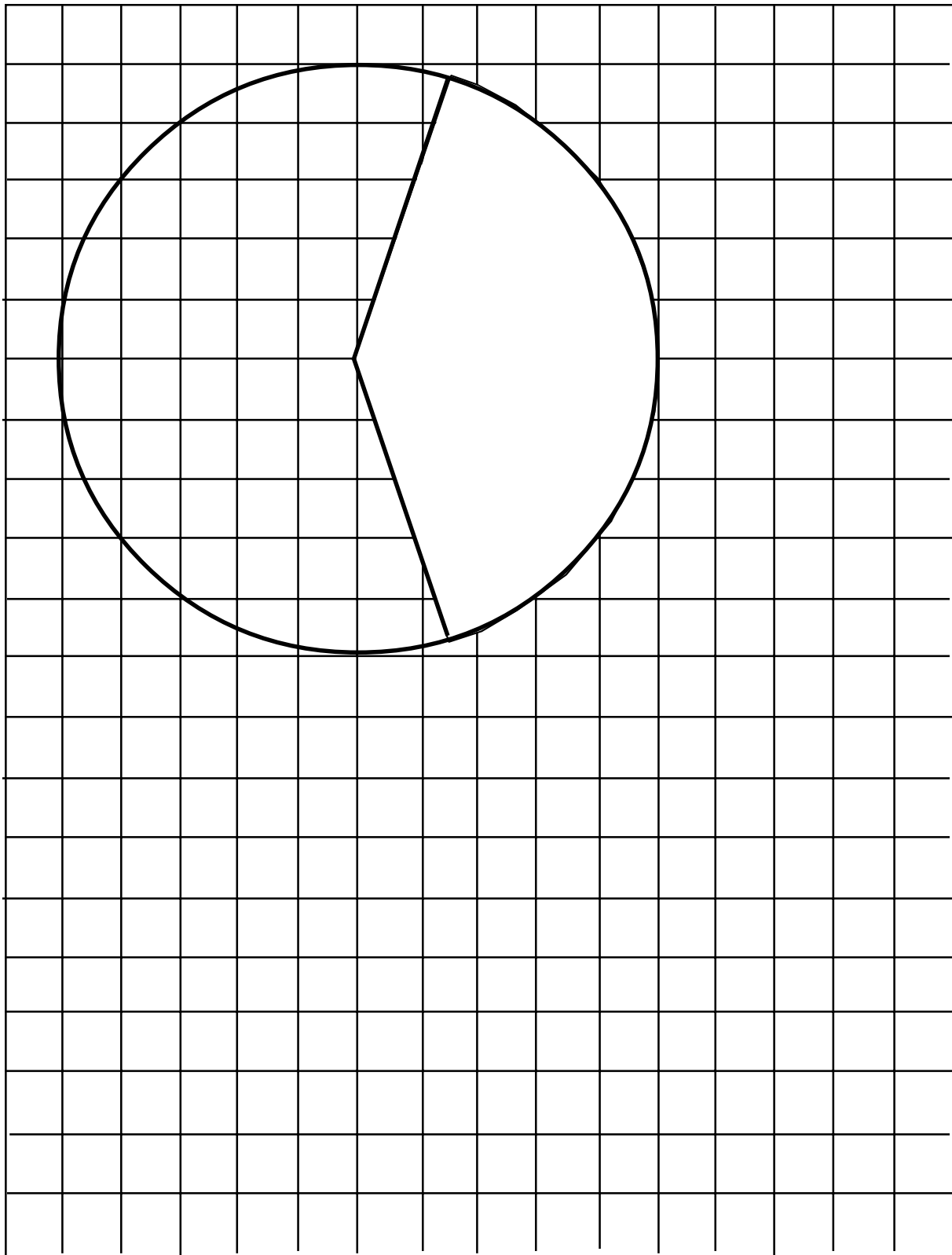

Name _____ Date _____

CYLINDER

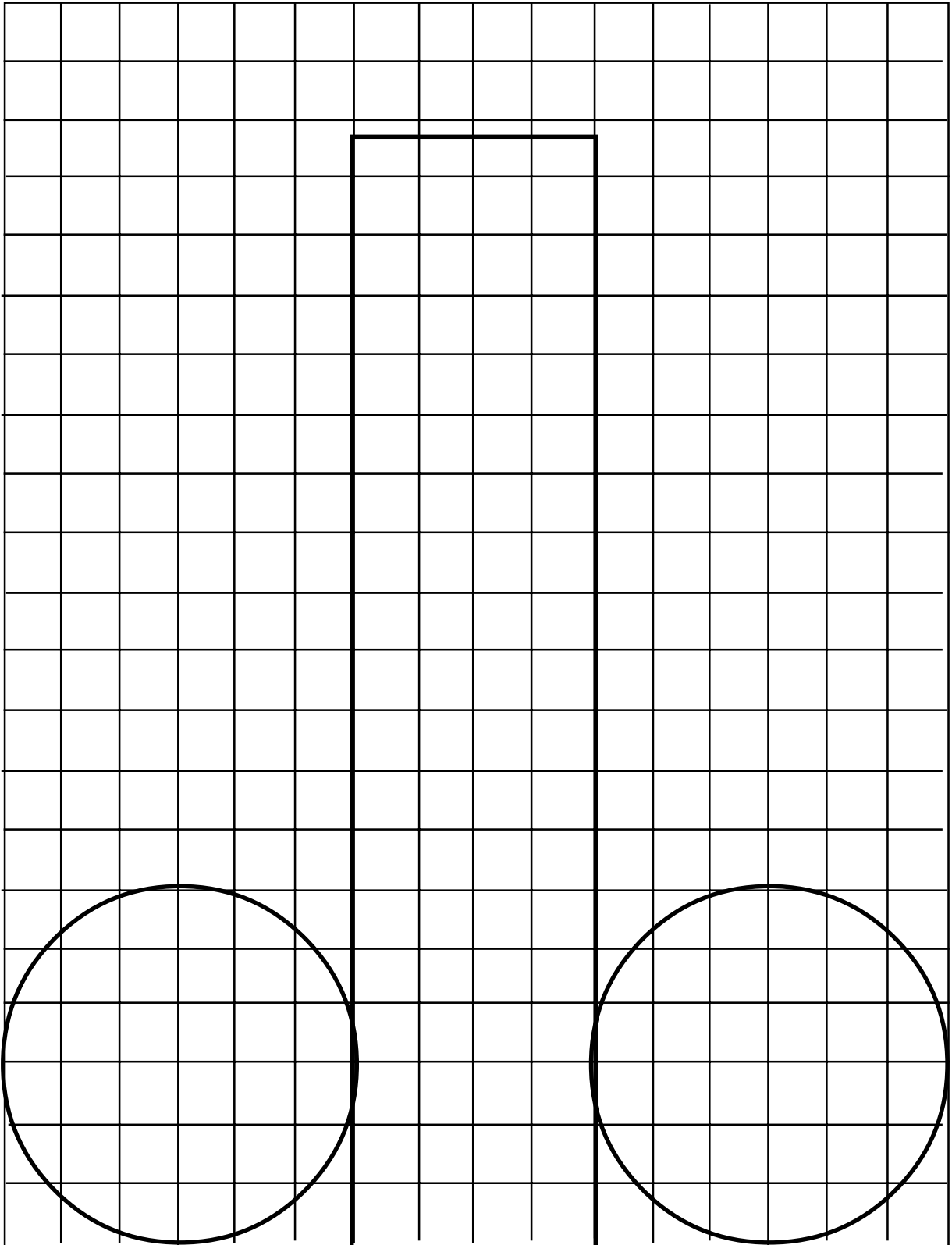

Cylinders Surround Us

- Olives come packed in containers of many different sizes. One common size is a glass cylinder with a diameter of 8 cm and a height of 9 cm. Some olives come packed in a cylinder with a diameter of only 6 cm. How tall would this cylinder have to be in order to have the same volume as the first one described?
- The bottom and sides of the olive jars are made of glass. The lid is made of metal. Find the cost of making the jars described in problem 1, if the glass jars can be made for 0.1 of a cent per square cm, and the metal lids can be made for 0.8 of a cent per square cm based on the size of the opening that they cover. Which one is the least expensive to make? What if the costs were 0.2 of a cent per square cm for the glass and 0.5 of a cent per square cm for the metal?
- Some olives come packed in a glass that looks like a truncated cone. Find the volume of olives that can be held in this glass container? Will it hold more or less than the cylinders described in problem 1?

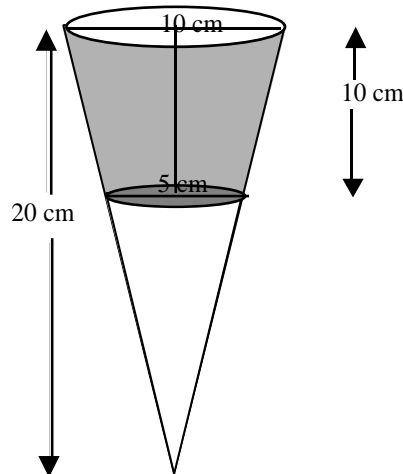

- Pencils are made of incense cedar. Each pencil is approximately 7 inches long and $\frac{5}{16}$ in diameter. A good size tree will make 300,000 pencils. Approximately how much wood is in 300,000 pencils? About 14 billion pencils are made in the world each year. How many trees are used to make these pencils?
- What is the surface area of a box made to hold a dozen pencils? Explore the various ways such a box could be designed.
- Solid copper weighs about 0.32 lbs per cubic inch. If 3.2 pounds of copper is going to be turned into a wire that has a diameter of 0.05 inches, how long will this wire be?
- A solid copper wire that has a diameter of 0.02 inches is 2,000 feet long. How much does this wire weigh?

A Look at Water Towers and Other Big Containers

Find the number of gallons of water each tank below can hold. One gallon of water is equal to 0.134 cubic feet.

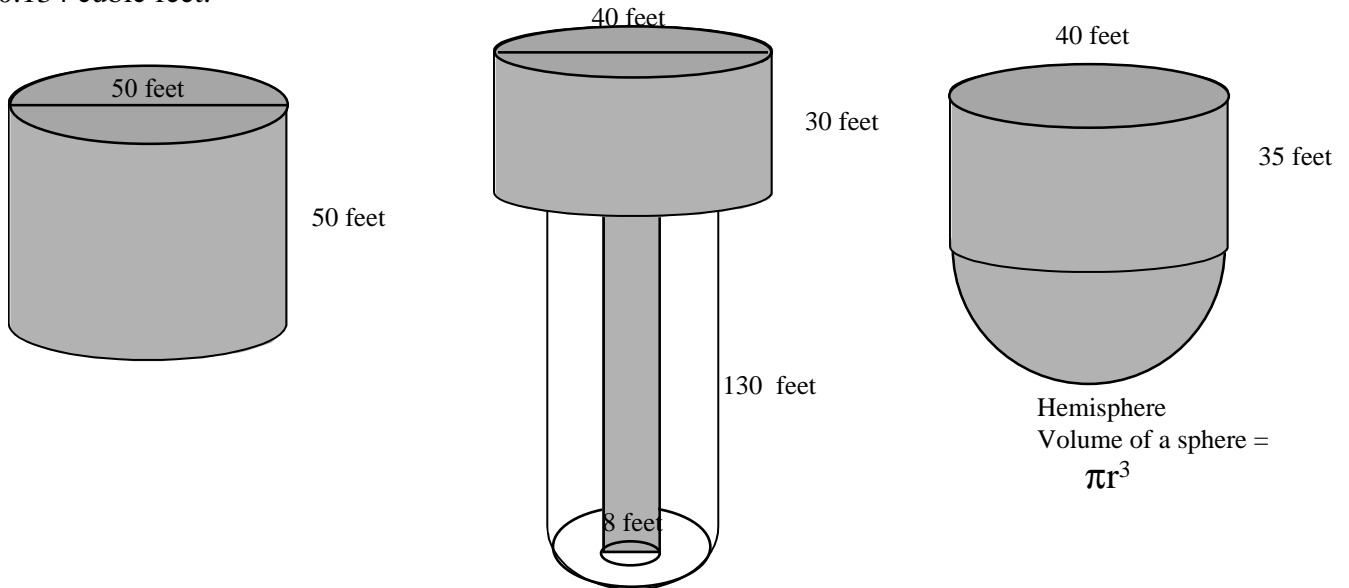

Below are two funnels used to transfer limestone from one place to another in a quarry. In each case the bottom of the funnel is a truncated cone. The limestone is pouring out at a rate of 200 cubic feet per minute. How long will it take the tanks to empty, if they start emptying when the shaded region is completely full? (The white cone at the bottom is not part of the tank. It is shown only to help you with your calculations.)

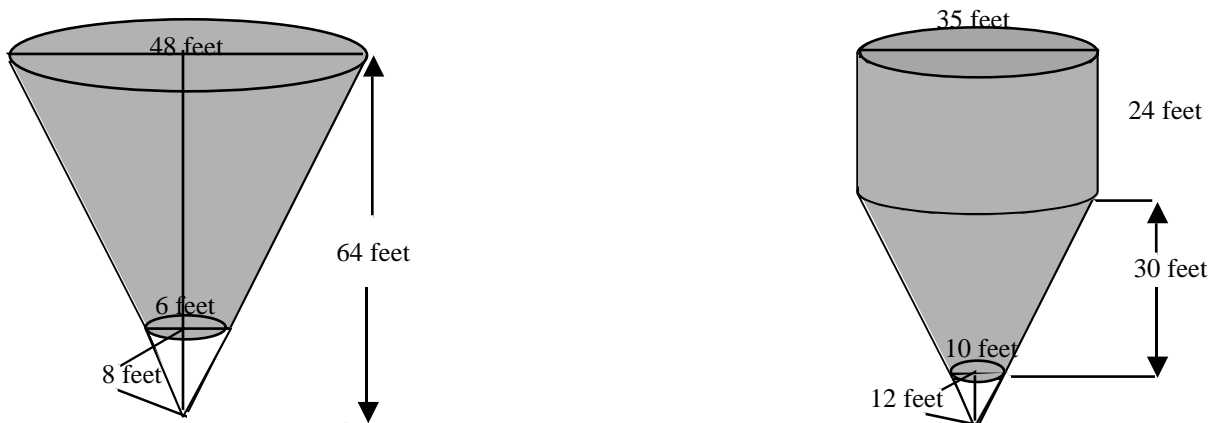

Cartoon Math

Objective: To create a scale drawing of your favorite cartoon.

Directions:

1. Select one frame from your favorite cartoon. (Preferably one that has simple figures.)
2. Grid the cartoon by measuring 0.5 centimeters vertically and horizontally. Make sure to use pencil. Label across the top using letters, and down the left side using numbers.
3. Make a grid on white drawing paper 2 centimeters vertically and horizontally. (Use a larger grid for a larger final cartoon.) Make sure you use pencil. Label across the top and down the left side using the same labels as your small cartoon.
4. Draw the cartoon onto the white drawing paper square by square using the grid.
5. Color your cartoon and display on poster board.

Cartoon Math Grading Rubric

Name _____

Category	Excellent	Good	Fair
Accuracy of Grid	3 Points	2 Points	1 Point
Accuracy of Drawing	3 Points	2 Points	1 Point
Presentation and Neatness	3 Points	2 Points	1 Point

Total

Total Points _____

Grading Scale:

- 9=100
- 8=95
- 7=90
- 6=85
- 5=80
- 4=75
- 3=70

Final Grade _____

Cartoon Math Grading Rubric

Name _____

Category	Excellent	Good	Fair
Accuracy of Grid	3 Points	2 Points	1 Point
Accuracy of Drawing	3 Points	2 Points	1 Point
Presentation and Neatness	3 Points	2 Points	1 Point

Total

Total Points _____

Grading Scale:

- 9=100
- 8=95
- 7=90
- 6=85
- 5=80
- 4=75
- 3=70

Final Grade _____

Name _____ Date _____

Soups-R-Us has created a new soup and they now need to design a new soup can. They are debating between two choices:

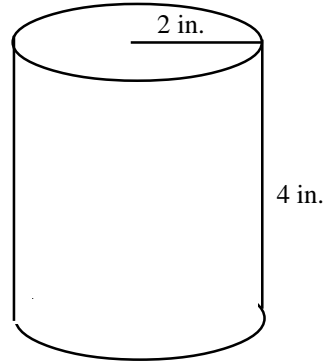
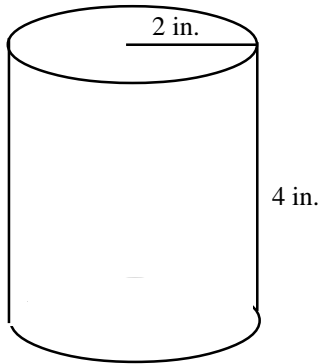

Choice #1: Regular soup
Can made w/ metal.

Choice #2: Regular soup
Can made w/ metal, and
with a plastic top.

If Soups-R-Us is to make 100 trial soup cans, how much money would they save by using Choice #2? Assume metal costs \$0.13 per square inch. (Assume plastic costs less than metal and disregard the cost of the plastic top for this calculation.)

Surface Area of a cylinder = $2\pi r^2 + 2\pi rh$

Area	Formula	Your Calculation	Square Inches
Can Bottom			
Can Top			
Curved Surface			
Total	$2\pi r^2 + 2\pi rh$		

Total Cost for Choice #1 = Square Inches _____ x 0.13 = _____

How will your calculation differ for Choice #2?

Total Cost for Choice #2 = Square Inches _____ x 0.13 = _____

How much money is saved by using Choice #2? _____

Volume - 1

Find each volume below.

1. The volume of cylinder A is 25 cubic cm. Find the volumes of cylinders B and C.

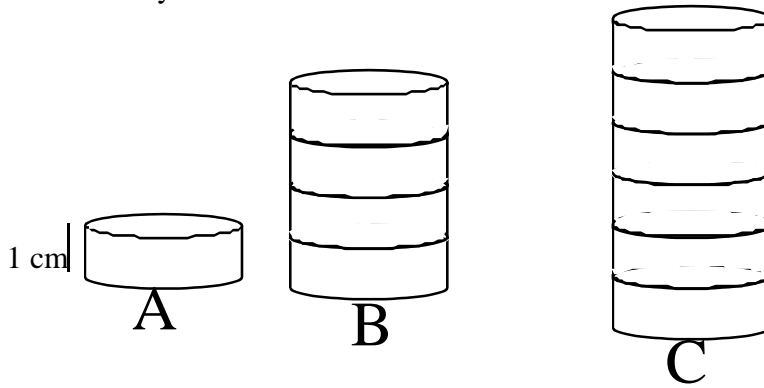

2. The volume of prism A is 36 cubic cm. Find the volumes of prisms B and C.

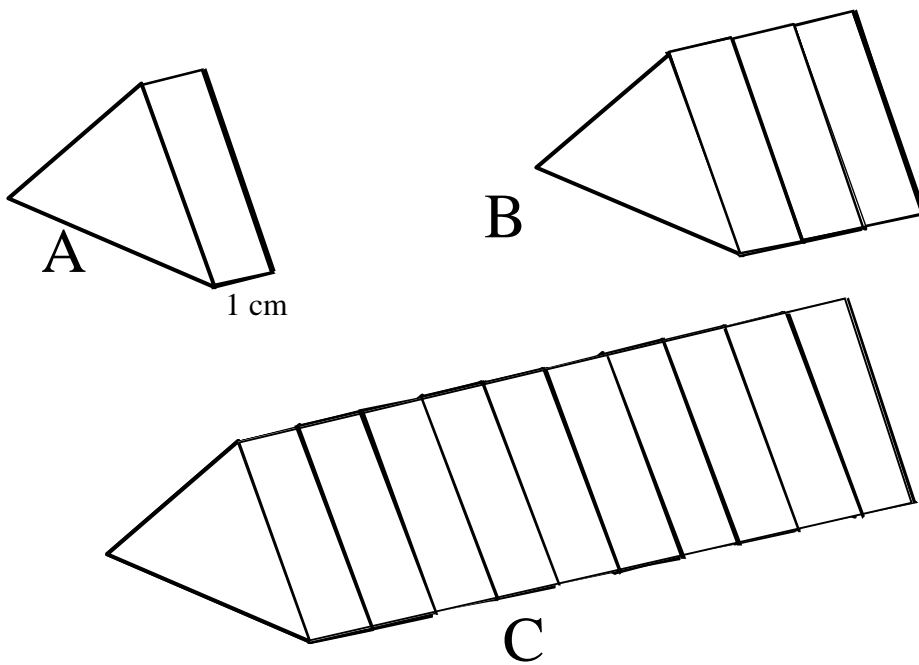

Volume -

Find each volume below.

1. Find the volume of the rectangular solid shown.

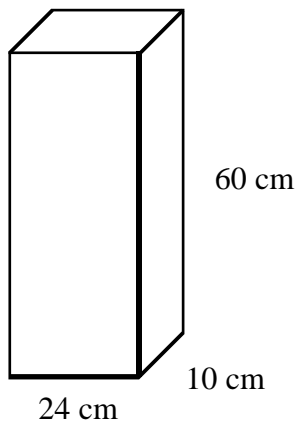

2. Find the volume of the prisms below.

